

USER MANUAL

4. Wiring Diagram

-Ballast Case must be Grounded

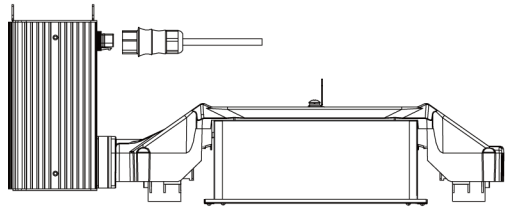

5. Protections

1. End of Lamp Life (EOL) Protection
2. Short circuit protection
3. Open circuit protection
4. Ignition failure protection
5. Thermal protection

6. Warning

Power surge, power outage, outage overloading may stress or damage the lamp. As a safety feature, this Soft-Start technology also reduces ballast damage caused by a bulb failure. In case of an unexpected shut-off, please disconnect from the power supply, remove the faulty lamp, check for wiring problems, then plug-in the ballast power cord.

7. Disclaimer

Any of following circumstances, will not be warranty:

1. Install the product without following the wiring diagram in this manual and cause the product damage.
2. Damaged by human reason (like product is soaked in water) or caused by not following the manual instructions.
3. Install or use the product without following the local laws and regulations.
4. Cover the warrant logo personally, or the client /the third party tries to maintain, repair, change the product and cause the damage.
5. Use of the environment does not meet the provisions of this manual.
6. Damaged by force majeure, like abnormal voltage, earthquake, flood, fire, thunderstroke, transportation accidents, etc.
7. Man-made damage during carrying, transportation.
8. Damaged by unstable match from other company' poor design or defective quality products. (like luminaire).
9. Beyond the warranty period.



1000W DOUBLE ENDED COMPLETE GROW LIGHT SYSTEM 347V

USER MANUAL

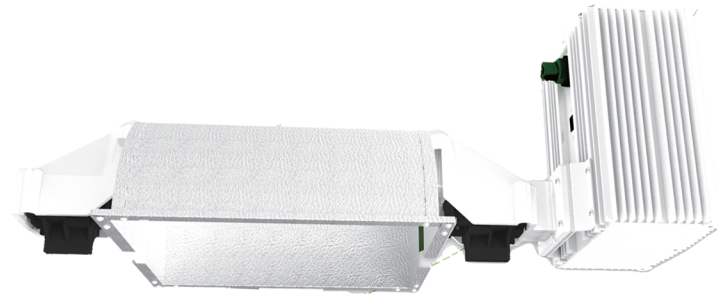

Product Advantage

- Generator ready
- Runs MH or HPS lamps
- High efficiency electronic ballast
- No acoustic resonance
- Lower harmonic distortion
- High output and improved spectrum
- Driver efficiency at full power: 96-97%
- Dimmable and Multi-Wattage with boost
- Completely sealed against dust and moisture
- Completely silent, light-weight and high energy-efficient.

USER MANUAL

1.Introduction

Thank you for purchasing Electronic Ballast. Please review the following instructions to ensure you receive the best performance. Each ballast uses a high temperature, resin-sealed component board for completely silent operation. Each unit is burned-in at the factory for approximately twelve hours to ensure maximum reliability.

Ballasts use a micro-processor similar to your home computer. This micro-processor allows the Ballast to run halide or sodium lamps. It is programmed for a "soft-start" and does not require an initial surge of power to light the lamp. This increase the lamp life and allows the end user to start multiple ballasts at the same time without tripping breakers. To ensure safe operation, this programmed for a "soft-start" and does not require an initial surge of power to light or missing lamp. In case of auto-shutoff, please disconnect from the power supply, remove the faulty lamp or check for wiring problems, wait for some minutes then restart your ballast.

2.Controls, connections and indications

- A. Electronic ballast
- B. Lamp socket
- C. Reflector
- D. Lever to unlatch reflector
- E. Terminal interface

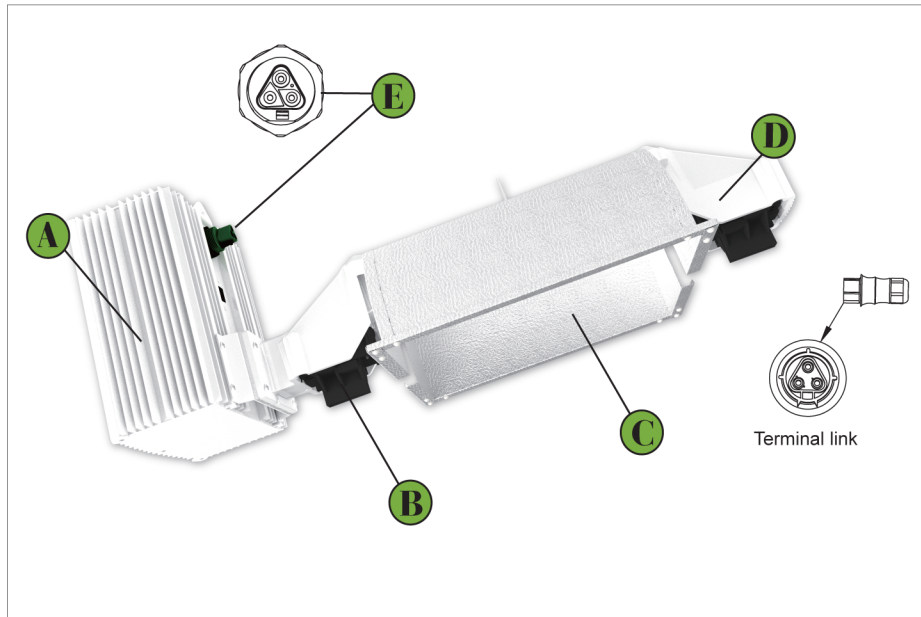

USER MANUAL

3.Product information

3.1. Technical specifications

Version	1000W/347V
Product weight	4.67kg/10.30lb
Dimensions (L*W*H)	585mm*247mm*249mm/23.0"*9.72"*9.80"
Temperature case	75 °C /167 °F
Temperature ambient	-20 ~+40 °C /-4 ~+104 °F
Input voltage +/-10%	347V
Input current at 1000W	3.07A
Input power at 1000W	1040W
Power factor	>0.99
Total Harmonic Distortion	<10%
Frequency	50/60Hz
Ignition voltage:	5 kv

3.2.Main Dimension

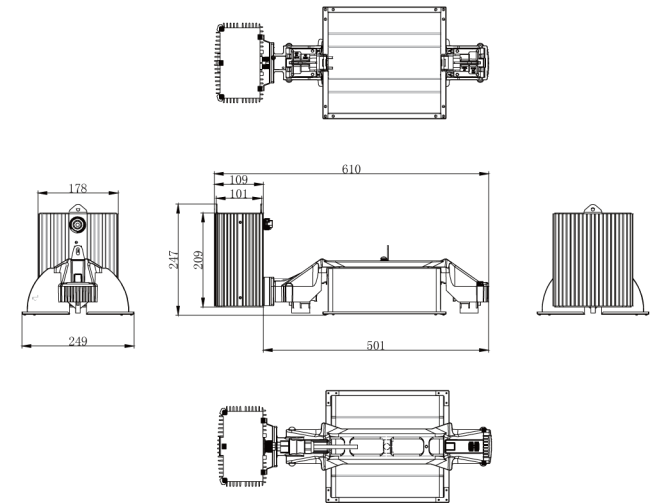

3.3.HOT SPOT

Tcase max=75°C/167°F

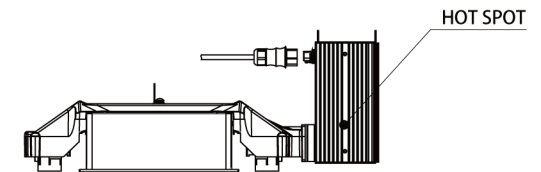

3.4.Environment

The product is meant for use in climate rooms. The product may be used in damp environments. The product may not be used in wet environments or outdoors. The 1000 W lamps function optimal when the ambient temperature is between -20 ~ 40°C / -4 ~ 104 °F.

IMPORTANT PRODUCT INFORMATION

READ IMMEDIATELY

SAFETY FIRST!

Failure to observe the following safety warnings may result in serious injury or death. Use all products only as directed. Failure to observe these safety warnings will result in a waiver of any and all liability on the part of its manufacturer, and resellers, and will void all warranties to the extent permitted by law.

WARNINGS AND INSTRUCTIONS

FOR USE:

- Disconnect power before re-lamping.
- When re-lamping, make sure lamp has time to cool before touching.
- Make sure power cord is connected properly.
- **DO NOT** hang ballast by power cord or lamp cord.
- **DO NOT** make contact with the interior of the socket while the power is on.
- **DO NOT** plug or unplug a lamp cord while the ballast is turned on.
- **ALWAYS** unplug the ballast from the power source before connecting or disconnecting any lighting device to ballast, moving ballast, or otherwise touching or handling ballast or its components.
- **DO NOT** use with generators. Warranty will be voided.
- **NEVER** stand beneath the ballast.
- **NEVER** put hands or any other objects in the interior of the ballast.
- **DO NOT** operate this or any lighting system in wet areas.
- **NEVER** get the ballast wet or allow it to come into contact with water or any other liquids.
- **NEVER** drop, shake or jostle the ballast.
- **NEVER** attempt to insulate or otherwise cover the ballast, as it releases a great deal of heat and may cause a fire or other damage. Ballasts should always have plenty of room to breathe and good ventilation around them.
- **DO NOT** plug this system into a supply voltage other than what is instructed on your fixture.
- **DO NOT** attempt open or rewire the components of the light system. It will void the warranty and may cause serious injury or death.
- **NEVER** attempt to rewire or alter any internal or external mechanisms or components on the ballast. This includes trying to cut and/or rewire the cords.
- If any part of the lamp is damaged, replace lamp immediately.
- Disconnect the unit from a power source before replacing lamps or any other parts.
- When replacing lamps, make sure the lamp has had time to cool before touching.
- Make sure power cord and lamp cord are connected securely to the unit.
- These products operate at very high temperatures. Keep away from children.
- Glass is required for reflectors using metal halide (MH) lamps for UL listing to apply. Glass is not required for high pressure sodium (HPS) lamps to be UL listed.
- Always use a three prong timer rated for 15 amps or more with light systems.
- Do not operate lamps that are a different wattage than the ballast specifies.
- Read all instructions completely before attempting to power on unit. Failure to follow the warnings and instructions for use may result in serious injury or death, for which the manufacturer and resellers expressly disclaim any and all liability.

2 Year Limited Warranty Service

If the product will not work after you have read the troubleshooting guide and practiced the troubleshooting options, you are advised to return the light system to the retailer you purchased it from. The dealer will be able to examine the light and test its components. If they are not able to repair the light, they will return it to us for examination and repair/replacement. Do not attempt to repair any product on your own, as serious injury or death may result. If the retailer is not able to help you and the light is still under manufacturer's warranty, you may contact us for technical support. In some cases, you will be issued an RMA# (return merchandise authorization number) to return the unit for factory repair. Complete the warranty form below and return the light with all original packaging, your receipt of purchase, and a valid RMA# to the address below. Please pack and ship the light in its original packaging. If it is damaged in shipment we cannot be responsible and the warranty may be voided. Once we receive RMA package, it will be repaired or replaced and shipped back to you. Please note if an additional warranty was purchased and include the extended warranty sales receipt with your return.

RETURN FORM

Include the following if returning:

- ✓ Proof of purchase
- ✓ This completed form
- ✓ RMA# on the outside of the box
- ✓ Extended warranty receipt

Return Merchandise Authorization Number (Required): _____

Contact Name: _____

Address: _____

Phone #: _____

Email Address: _____

Please give a brief description of your technical issue: _____

UPDATE ADDRESS:

RMA Dept.
17128 Colima Road Suite 510
Hacienda Heights, CA 91745
714-516-8176